

Features and Benefits

The SLT3S Tester is a rugged, lightweight product designed to verify the integrity of 1-, 2-, 3-, and 4-pair UTP or STP channels. Incorporating a unique 3-in-1 design, this tester features built-in modular jacks for USOC, 568A and 568B wiring sequences, thus eliminating the need to attach separate converters or adapters. Powered by a 9 volt battery, this compact hand-held tester is ideal for anyone who designs, installs, or tests cabling systems.

The master and remote units separate for end-to-end testing of installed cabling. Shorts, opens, reversals, or mis-wires are easily detected within seconds – the continuously-sequencing LED display immediately highlights any problems in the cabling system. Both pieces simply snap and lock together and a proximity switch disconnects the battery when not in use.

Designed to fit neatly into a tool box or pocket, the SLT3S tester has a convenient “ring” feature for attaching to a belt or frame. A durable nylon carry case is available as an optional accessory. Frame adapters are available for testing from the punch down block to the wall plate in one simple operation.

The Master and Remote units provide end-to-end testing of installed cabling. The SLT3S checks each channel from the Station Device to the System. In addition the SLT3S can test all line cords.

The SLT3S tester verifies or indicates wiring errors on 2-, 3- and 4-pair UTP and STP channels. The continually sequencing LED display provides instant indication of any shorts, opens, reversals, and mis-wires.

- Innovative 3-in-1 design features modular jacks for testing USOC, 568A and 568B cabling systems
- Accurately verifies the continuity and sequence of 1-, 2-, 3, and 4 pair UTP and STP channels
- Continuously-sequencing LED display provides a diagnostic readout that immediately detects shorts, opens, reversals and mis-wires at a glance
- Simply snap and lock master and remote units together when not in use
- Ergonomically designed hand-held unit is lightweight, rugged, and impact-resistant
- 9 Volt alkaline battery included
- Carry case and accessories kit available
- Adapters are available for IBM cabling systems and AT&T 110 systems
- SLT3S performs shield continuity on STP systems

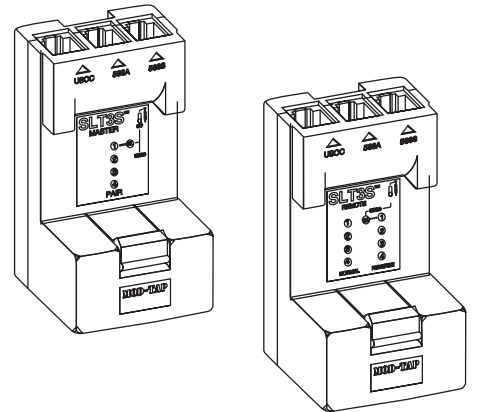

SLT3S DIAGNOSTICS

Master	Remote	Diagnosis
LED on	LED on	Good channel
LED on	LED on red	Reversal
LED on	LED off	Short within pair
2 LEDs on	2 LEDs on	Short between pairs
LED off	LED off	Open
LED out of sequence	LED out of sequence	Transposed pairs
STP Testing Only		
Master	Remote	
GREEN 1 and OK LED's ON		GREEN OK LED ON

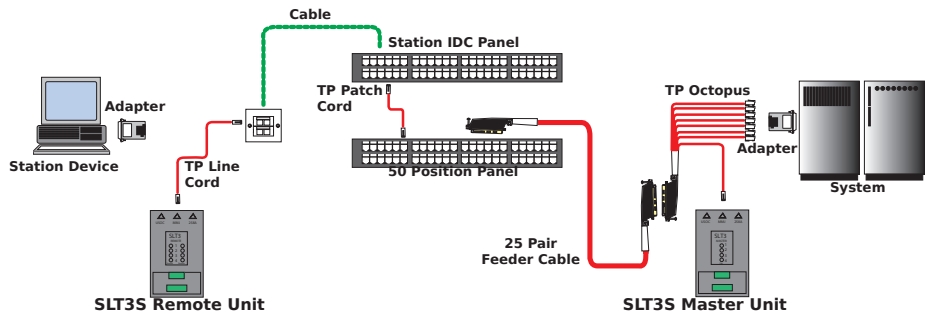

ORDERING INFORMATION

Order No.	SAP No.	Description
33A-100-10	Consult Molex	SLT3S Shielded Tester with 9 Volt battery (U.K.)
33-100-P	Consult Molex	SLT3 Carry Case
33A-100-11	Consult Molex	SLT3S Tester (French)
33A-100-12	Consult Molex	SLT3S Tester (Italy)

MOLEX PREMISE NETWORKS

Americas
Tel: 630 969 4550
www.molexpn.com

EMEA
Tel: 44 (0)2392 205800
www.molexpn.co.uk

APAC
Tel: 61 3 9971 7111
www.molexpn.com.au