

# IX5-28GPX

## High Availability Video Surveillance Switch

The Allied Telesis IX5-28GPX offers an impressive set of features in a high-value package, making it ideal for IP video surveillance environments.



### Overview

The Allied Telesis IX5-28GPX provides a high performing and scalable solution for today's networks. With 24 PoE+ enabled 10/100/1000Mbps ports, two 1/10 Gigabit uplinks, plus the ability to stack up to four units, the IX5-28GPX is the ideal solution for video surveillance applications where high performance and resilient PoE power are critical.

### High availability

The IX5-28GPX was designed with reliability in mind. It guarantees continual delivery of data and streaming video. Dual hot-swappable load-sharing power supplies provide resilient system and end-point power, with up to 30 Watts available to power today's pan, tilt and zoom cameras. Factor in the ability to operate at up to 60°C, and the IX5 is an easy choice for modern video surveillance environments.



### Network resiliency

The convergence of network services in the enterprise has led to increasing demand for highly available networks with minimal downtime. VCStack, in conjunction with link aggregation, provides a network with no single point of failure and an easy, resilient solution for high availability applications. The IX5-28GPX can form a VCStack of up to four units for enhanced resiliency and simplified device management.

Allied Telesis Ethernet Protection Switched Ring (EPSRing™), and the standards-based G.8032 Ethernet Ring Protection, ensure that distributed network segments have high-speed, resilient access to online resources and applications.

Ring Protection and VCStack-LD (Long Distance), which enables stacks to be

created over long distance fiber links, make the IX5-28GPX the perfect choice for distributed environments.

### Simplified network management

Modern converged networks have increasing management requirements. Allied Telesis Autonomous Management Framework (AMF) automates many everyday tasks, including configuration management, saving you valuable time and resources. The complete network can be managed as a single virtual device with powerful centralized management features. Growing the network can be accomplished with plug-and-play simplicity, and network node recovery is fully zero-touch.

AMF secure mode increases network security with management traffic encryption, authorization, and monitoring.

### Advanced operating system

The IX5-28GPX runs the advanced AlliedWare Plus™ fully featured operating system, delivering a rich feature set and an industry-standard CLI. The industry-standard CLI reduces training requirements and is consistent across all AW+ devices, simplifying network management.

### Secure

Advanced security features protect the network from the edge to the core. Unprecedented control over user access is provided with Network Access Control (NAC), to mitigate threats to network infrastructure. This ensures the network is accessed only by known users and devices - users' adherence to network security policies is checked, and either access is granted or remediation is offered. Secure access can also be provided for guests. A secure network

environment is guaranteed, with powerful control over network traffic types, secure management options, and other multi-layered security features built right into the IX5-28GPX switch.

### Future-proof

The flexibility of the IX5-28GPX, coupled with the ability to seamlessly add new nodes to a VCStack of multiple units, ensures a future-proof network. The IX5-28GPX comes with a comprehensive IPv6 feature set, ensuring it is ready for future network traffic demands.

### Eco-friendly

The IX5-28GPX supports Energy Efficient Ethernet, which automatically reduces the power consumed by the switch whenever there is no traffic on a port. This sophisticated feature can significantly reduce operating costs, by reducing the power requirements of the switch and any associated cooling equipment.



## New Features

- ▶ AMF secure mode
- ▶ G.8032 Ethernet Ring Protection
- ▶ Ethernet CFM
- ▶ ACLs for management traffic
- ▶ Active Fiber Monitoring
- ▶ Microsoft Network Load Balancing (MS NLB) support
- ▶ VLAN Mirroring (RSPAN)





## Key Features

### Reliable

- ▶ Dual hot-swappable load-sharing power supplies maximize network uptime, ensuring a resilient solution where always-on access is required.

### Allied Telesis Autonomous Management Framework (AMF)

- ▶ Allied Telesis Autonomous Management Framework (AMF) is a sophisticated suite of management tools that provide a simplified approach to network management. Common tasks are automated or made so simple that the every-day running of a network can be achieved without the need for highly-trained, and expensive, network engineers. Powerful features like centralized management, auto-backup, auto-upgrade, auto-provisioning and auto-recovery enable plug-and-play networking and zero-touch management.
- ▶ AMF secure mode encrypts all AMF traffic, provides unit and user authorization, and monitors network access to greatly enhance network security.

### VCStack™(Virtual Chassis Stacking)

- ▶ Create a VCStack of up to four IX5 units with 40Gbps of stacking bandwidth to each unit. VCStack provides a highly available system where network resources are spread out across stacked units, reducing the impact if one of the units fails. Aggregating switch ports on different units across the stack provides excellent network resiliency.

### Long-distance Stacking

- ▶ Long-distance stacking allows a VCStack to be created over longer distances, perfect for a distributed network environment.

### EPSRing™(Ethernet Protection Switched Ring)

- ▶ EPSRing and 10 Gigabit Ethernet allow several IX5 switches to form a high-speed protected ring capable of recovery within as little as 50ms. This feature is ideal for large IP surveillance environments.
- ▶ Super-Loop Protection enables a link between two EPSR nodes to be in separate EPSR domains, improving redundancy and network fault resiliency.

### G.8032 Ethernet Ring Protection

- ▶ G.8032 provides standards-based high-speed ring protection, that can be deployed stand-alone, or interoperate with Allied Telesis EPSR.
- ▶ Ethernet Connectivity Fault Monitoring (CFM) proactively monitors links and VLANs, and provides alerts when a fault is detected.

### Industry-leading Quality of Service (QoS)

- ▶ Comprehensive low-latency wire speed QoS provides flow-based traffic management with full classification, prioritization, traffic shaping and min/max bandwidth profiles. Boosted network performance and guaranteed delivery of business-

critical Ethernet services and applications are provided. Time-critical services such as voice and video take precedence over non-essential services such as file downloads, maintaining responsiveness of Enterprise applications.

### Loop Protection

- ▶ Thrash limiting, also known as rapid MAC movement, detects and resolves network loops. It is highly user-configurable — from the rate of looping traffic to the type of action the switch should take when it detects a loop.
- ▶ With thrash limiting, the switch only detects a loop when a storm has occurred, which can potentially cause disruption to the network. To avoid this, loop detection works in conjunction with thrash limiting to send special Loop Detection Frame (LDF) packets that the switch listens for. If a port receives an LDF packet, the port, or link can be disabled, or an SNMP trap can be sent. This feature can help to detect loops before a network storm occurs, avoiding the risk and inconvenience of traffic disruption.

### Power over Ethernet Plus (PoE+)

- ▶ With PoE, a separate power connection to media endpoints such as IP phones and wireless access points is not necessary. PoE+ reduces costs and provides even greater flexibility, providing the capability to connect devices requiring more power (up to 30 Watts) such as, tilt and zoom security cameras.

### Link Layer Discovery Protocol – Media Endpoint Discovery (LLDP – MED)

- ▶ LLDP-MED extends LLDP basic network endpoint discovery and management functions. LLDP-MED allows for media endpoint specific messages, providing detailed information on power requirements, network policy, location discovery (for Emergency Call Services) and inventory.

### Voice VLAN

- ▶ Voice VLAN automatically separates voice and data traffic into two different VLANs. This automatic separation places delay-sensitive traffic into a voice- dedicated VLAN, which simplifies QoS configurations.

### sFlow

- ▶ sFlow is an industry-standard technology for monitoring high-speed switched networks. It provides complete visibility into network use, enabling performance optimization, usage accounting/billing, and defense against security threats. Sampled packets sent to a collector ensure it always has a real-time view of network traffic.

### VLAN Mirroring (RSPAN)

- ▶ VLAN mirroring allows traffic from a port on a remote switch to be analysed locally. Traffic being transmitted or received on the port is duplicated and sent across the network on a special VLAN.

### Dynamic Host Configuration Protocol (DHCP) Snooping

- ▶ DHCP servers allocate IP addresses to clients, and the switch keeps a record of addresses issued on each port. IP source guard checks against this DHCP snooping database to ensure only clients with specific IP and/or MAC address can access the network. DHCP snooping can be combined with other features, like dynamic ARP inspection, to increase security in Layer 2 switched environments, and also provides a traceable history, which meets the growing legal requirements placed on service providers.

### Tri-authentication

- ▶ Authentication options on the IX5 also include alternatives to IEEE 802.1x port-based authentication, such as web authentication to enable guest access and MAC authentication for endpoints that do not have an IEEE 802.1x supplicant. All three authentication methods— IEEE 802.1x, MAC-based and Web-based— can be enabled simultaneously on the same port for tri-authentication.

### Access Control Lists (ACLs)

- ▶ AlliedWare Plus delivers industry-standard Access Control functionality through ACLs. ACLs filter network traffic to control whether routed packets are forwarded or blocked at the port interface. This provides a powerful network security mechanism to select the types of traffic to be analyzed, forwarded, or influenced in some way.

### Optical DDM

- ▶ Most modern optical SFP/SFP+/XFP transceivers support Digital Diagnostics Monitoring (DDM) functions according to the specification SFF-8472. This enables real time monitoring of the various parameters of the transceiver, such as optical output power, temperature, laser bias current and transceiver supply voltage. Easy access to this information simplifies diagnosing problems with optical modules and fiber connections.

### Active Fiber Monitoring

- ▶ Active Fiber Monitoring prevents eavesdropping on fiber communications by monitoring received optical power. If an intrusion is detected, the link can be automatically shut down, or an operator alert can be sent.

### UniDirectional link Detection

- ▶ UniDirectional Link Detection (UDLD) is useful for monitoring fiber-optic links between two switches that use two single-direction fibers to transmit and receive packets. UDLD prevents traffic from being sent across a bad link by blocking the ports at both ends of the link in the event that either the individual transmitter or receiver for that connection fails.

## Key Solutions

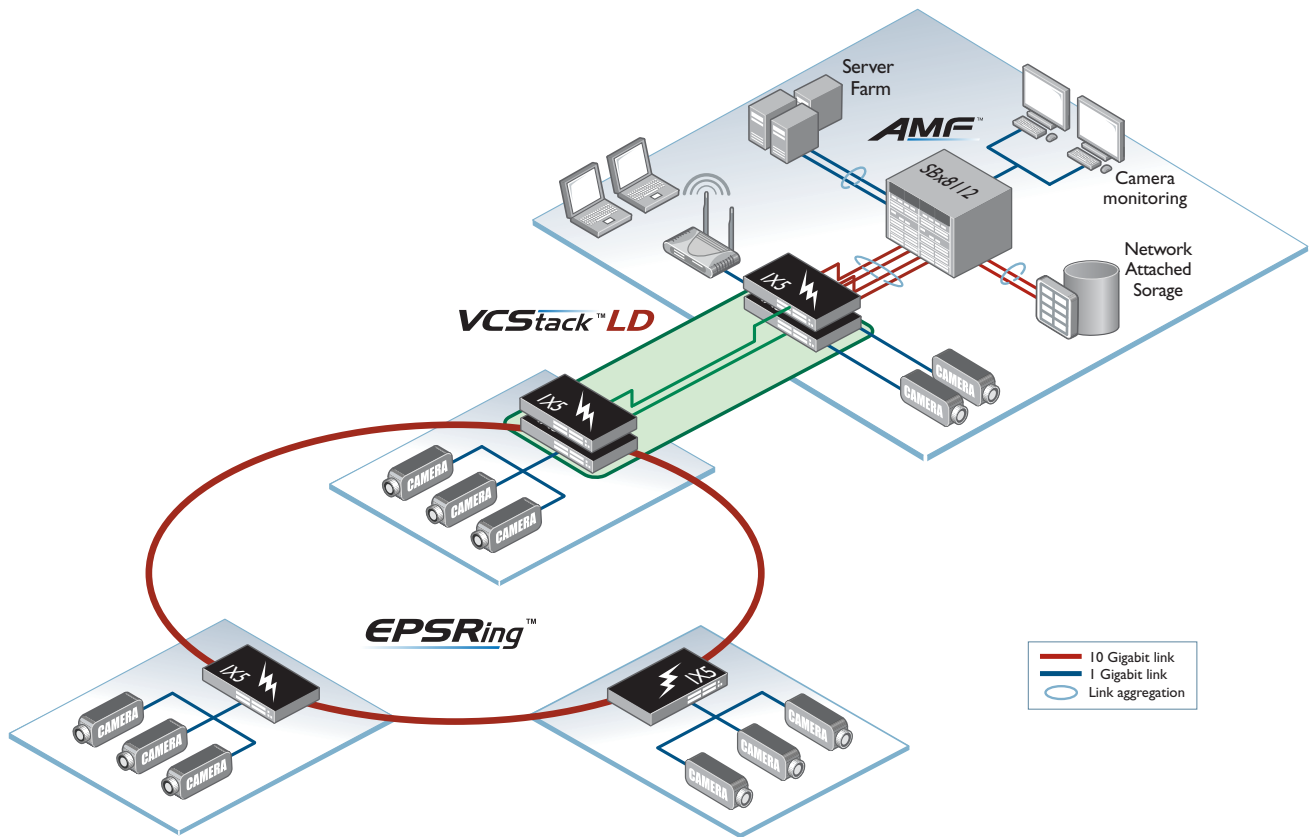

Diagram 1: IP Video Surveillance

### IP Video Surveillance

With the evolution of CCTV technology to digital IP-based systems, the emphasis has moved from simple video footage monitoring, to intelligent systems with video analytics capable of identifying abnormal events or behavior. As intelligence increases in these systems, so too do the applications for this technology – from retail outlets, warehouses and office buildings, to hotels, hospitals and advanced traffic monitoring systems.

Modern high definition digital images are sharper and clearer than ever before. Large amounts of digital video can be stored on Network-Attached Storage (NAS) systems, and digital images don't degrade over time.

Allied Telesis provides secure and resilient IP video surveillance network solutions. The key features of our AT-IX5-28GPX switch make it ideal for use in advanced surveillance systems:

- ▶ Dual hot-swappable load-sharing power supplies, and support for operation up to 60°C ensure maximum network uptime.
- ▶ Power over Ethernet (PoE+) provides up to 30 Watts to end-points, supporting the latest generation of pan, tilt and zoom IP cameras.
- ▶ High performance multicast support manages large numbers of digital video streams across the network.
- ▶ Long-Distance Virtual Chassis Stacking (VCStack-LD) is ideal to spread network distribution, while keeping total resilience.
- ▶ Ethernet Protection Switched Rings (EPSR) provides a high-speed ring topology with failover in a little as 50ms, supporting large IP surveillance environments with an 'always-on' solution.

With the AT-IX5-28GPX and other advanced switching products, Allied Telesis IP video surveillance solutions are dependable, scalable and ready for the next generation of digital monitoring technologies.

## Product Specifications

PRODUCT	10/100/1000T (RJ-45) COPPER PORTS	100/1000X SFP PORTS	1/10 GIGABIT SFP+ PORTS	10 GIGABIT STACKING PORTS	MAX POE+ PORTS	SWITCHING FABRIC	FORWARDING RATE
AT-IX5-28GPX	24	-	2	2*	24	128Gbps	95.2Mpps

\* Stacking ports can be configured as additional 1G/10G Ethernet ports when unit is not stacked

### Performance

- ▶ 40 Gbps of stacking bandwidth
- ▶ Supports 13kB Jumbo frames
- ▶ Wirespeed multicasting
- ▶ Up to 16K MAC addresses
- ▶ 512MB DDR SDRAM
- ▶ 64MB flash memory
- ▶ Packet Buffer memory: 2MB

### Reliability

- ▶ Modular AlliedWare Plus operating system
- ▶ Redundant power supplies load share providing uninterrupted power and extra reliability
- ▶ Full environmental monitoring of PSUs, fans, temperature and internal voltages. SNMP traps alert network managers in case of any failure

### Power Characteristics

- ▶ AC voltage: 90 to 260V (auto-ranging)
- ▶ Frequency: 47 to 63Hz

### Expandability

- ▶ Stackable up to four units of IX5 in a VCStack

### Flexibility and Compatibility

- ▶ 10G SFP+ ports will support any combination of Allied Telesis 1000Mbps SFP and 10GbE SFP+ modules and direct attach cables listed in this document under Ordering Information
- ▶ Stacking ports can be configured as 10G Ethernet ports
- ▶ Port speed and duplex configuration can be set manually or by auto-negotiation

### Diagnostic Tools

- ▶ Active Fiber Monitoring detects tampering on optical links
- ▶ Built-In Self Test (BIST)
- ▶ Find-me device locator
- ▶ Cable fault locator (TDR)
- ▶ UniDirectional Link Detection (UDLD)
- ▶ Automatic link flap detection and port shutdown
- ▶ Optical Digital Diagnostic Monitoring (DDM)
- ▶ Ping polling for IPv4 and IPv6
- ▶ Port and VLAN mirroring (RSPAN)
- ▶ TraceRoute for IPv4 and IPv6

### IPv4 Features

- ▶ Black hole routing
- ▶ Directed broadcast forwarding
- ▶ DNS relay
- ▶ Policy-based routing
- ▶ IPv4 static routing
- ▶ UDP broadcast helper (IP helper)

### IPv6 Features

- ▶ DHCPv6 relay, DHCPv6 client
- ▶ DNSv6 relay, DNSv6 client
- ▶ IPv4 and IPv6 dual stack
- ▶ IPv6 hardware ACLs

- ▶ Device management over IPv6 networks with SNMPv6, Telnetv6 and SSHv6
- ▶ NTPv6 client and server
- ▶ IPv6 static routing

### Management

- ▶ Front panel 7-segment LED provides at-a-glance status and fault information
- ▶ Allied Telesis Management Framework (AMF) enables powerful centralized management and zero-touch device installation and recovery
- ▶ Console management port on the front panel for ease of access
- ▶ Eco-friendly mode allows ports and LEDs to be disabled to save power
- ▶ Web-based Graphical User Interface (GUI)
- ▶ Industry-standard CLI with context-sensitive help
- ▶ Powerful CLI scripting engine and built-in text editor
- ▶ Comprehensive SNMP MIB support for standards-based device management
- ▶ Event-based triggers allow user-defined scripts to be executed upon selected system events
- ▶ USB interface allows software release files, configurations and other files to be stored for backup and distribution to other devices

### Quality of Service (QoS)

- ▶ 8 priority queues with a hierarchy of high priority queues for real time traffic, and mixed scheduling, for each switch port
- ▶ Limit bandwidth per port or per traffic class down to 64kbps
- ▶ Wirespeed traffic classification with low latency essential for VoIP and real-time streaming media applications
- ▶ Policy-based QoS based on VLAN, port, MAC and general packet classifiers
- ▶ Policy-based storm protection
- ▶ Extensive remarking capabilities
- ▶ Taildrop for queue congestion control
- ▶ Strict priority, weighted round robin or mixed scheduling
- ▶ IP precedence and DiffServ marking based on layer 2, 3 and 4 headers

### Resiliency

- ▶ Stacking ports can be configured as 10G Ethernet ports
- ▶ Control Plane Prioritization (CPP) ensures the CPU always has sufficient bandwidth to process network control traffic
- ▶ Dynamic link failover (host attach)
- ▶ EPSRing (Ethernet Protection Switched Rings) with SuperLoop Protection (SLP)
- ▶ EPSR enhanced recovery for extra resiliency
- ▶ Long-Distance stacking (LD-VCStack)
- ▶ Loop protection: loop detection and thrash limiting
- ▶ PVST+ compatibility mode
- ▶ STP root guard
- ▶ VCStack fast failover minimizes network disruption

### Security

- ▶ Access Control Lists (ACLs) based on layer 3 and 4 headers
- ▶ Configurable ACLs for management traffic
- ▶ Auth-fail and guest VLANs
- ▶ Authentication, Authorisation and Accounting (AAA)
- ▶ Bootloader can be password protected for device security
- ▶ BPDU protection
- ▶ DHCP snooping, IP source guard and Dynamic ARP Inspection (DAI)
- ▶ DoS attack blocking and virus throttling
- ▶ Dynamic VLAN assignment
- ▶ MAC address filtering and MAC address lock-down
- ▶ Network Access and Control (NAC) features manage endpoint security
- ▶ Port-based learn limits (intrusion detection)
- ▶ Private VLANs provide security and port isolation for multiple customers using the same VLAN
- ▶ Secure Copy (SCP)
- ▶ Strong password security and encryption
- ▶ Tri-authentication: MAC-based, web-based and IEEE 802.1x
- ▶ RADIUS group selection per VLAN or port

### Environmental Specifications

- ▶ Operating temperature range: 0°C to 50°C (32°F to 122°F) nominal  
0°C to 60°C (32°F to 140°F) with 2 x PWR800 and 250W PoE max.  
Derated by 1°C per 305 meters (1,000 ft)
- ▶ Storage temperature range: -25°C to 70°C (-13°F to 158°F)
- ▶ Operating relative humidity range: 5% to 90% non-condensing
- ▶ Storage relative humidity range: 5% to 95% non-condensing
- ▶ Operating altitude: 3,048 meters maximum (10,000 ft)

### Electrical Approvals and Compliances

- ▶ EMC: EN55022 class A, FCC class A, VCCI class A, ICES-003 class A
- ▶ Immunity: EN55024, EN61000-3-levels 2 (Harmonics), and 3 (Flicker) – AC models only

### Safety

- ▶ Standards: UL60950-1, CAN/CSA-C22.2 No. 60950-1-03, EN60950-1, EN60825-1, AS/NZS 60950.1
- ▶ Certification: UL, cUL

### Restrictions on Hazardous Substances (RoHS) Compliance

- ▶ EU RoHS compliant
- ▶ China RoHS compliant

### Country of Origin

- ▶ China





**Physical Specifications and MTBF Figures**

PRODUCT	WIDTH X DEPTH X HEIGHT	MOUNTING	WEIGHT		PACKAGED DIMENSIONS
			UNPACKAGED	PACKAGED	
AT-IX5-28GPX	440 x 480 x 44 mm 17.32 x 18.89 x 1.73 in)	1RU Rack-mount	5.4 kg (11.91 lb)	7.4 kg (16.32 lb)	58 x 56 x 15 cm 22.8 x 22.0 x 5.9 in)

**Power and Noise Characteristics**

PRODUCT	NO POE LOAD			FULL POE+ LOAD		
	MAX POWER CONSUMPTION	MAX HEAT DISSIPATION	NOISE	MAX POWER CONSUMPTION	MAX HEAT DISSIPATION	NOISE
AT-IX5-28GPX	81W	276 BTU/h	44 dBA	626W	703 BTU/hr	52 dBA

Noise: tested to ISO7779; front bystander position

**Latency (microseconds)**

PRODUCT	PORT SPEED			
	10MBPS	100MBPS	1GBPS	10GBPS
AT-IX5-28GPX	66µs	9.3µs	3.9µs	3.0µs

**PSU PoE Options**

PSU	MAX POE POWER	MAX POE PORTS AT 15W PER PORT	MAX POE+ PORTS AT 30W PER PORT
1 x AT-PWR800	370w	24	12
2 x AT-PWR800	720w	24	24

**Standards and Protocols**

**AlliedWare Plus Operating System**

Version 5.4.7-1

**Cryptographic Algorithms**

**FIPS Approved Algorithms**

Encryption (Block Ciphers):

- ▶ AES (ECB, CBC, CFB and OFB Modes)
- ▶ 3DES (ECB, CBC, CFB and OFB Modes)

Block Cipher Modes:

- ▶ CCM
- ▶ CMAC
- ▶ GCM
- ▶ XTS

Digital Signatures & Asymmetric Key Generation:

- ▶ DSA
- ▶ ECDSA
- ▶ RSA

Secure Hashing:

- ▶ SHA-1
- ▶ SHA-2 (SHA-224, SHA-256, SHA-384, SHA-512)

Message Authentication:

- ▶ HMAC (SHA-1, SHA-2(224, 256, 384, 512)

Random Number Generation:

- ▶ DRBG (Hash, HMAC and Counter)

**Non FIPS Approved Algorithms**

RNG (AES128/192/256)  
DES  
MD5

**Ethernet**

IEEE 802.2 Logical Link Control (LLC)  
IEEE 802.3 Ethernet  
IEEE 802.3ab1000BASE-T  
IEEE 802.3ae10 Gigabit Ethernet  
IEEE 802.3af Power over Ethernet (PoE)  
IEEE 802.3at Power over Ethernet plus (PoE+)  
IEEE 802.3az Energy Efficient Ethernet (EEE)  
IEEE 802.3x Flow control - full-duplex operation  
IEEE 802.3z 1000BASE-X

**IPv4 Features**

RFC 768 User Datagram Protocol (UDP)  
RFC 791 Internet Protocol (IP)  
RFC 792 Internet Control Message Protocol (ICMP)  
RFC 793 Transmission Control Protocol (TCP)  
RFC 826 Address Resolution Protocol (ARP)  
RFC 894 Standard for the transmission of IP datagrams over Ethernet networks  
RFC 919 Broadcasting Internet datagrams  
RFC 922 Broadcasting Internet datagrams in the presence of subnets  
RFC 932 Subnetwork addressing scheme  
RFC 950 Internet standard subnetting procedure  
RFC 951 Bootstrap Protocol (BootP)  
RFC 1027 Proxy ARP  
RFC 1035 DNS client  
RFC 1042 Standard for the transmission of IP datagrams over IEEE 802 networks  
RFC 1071 Computing the Internet checksum  
RFC 1122 Internet host requirements  
RFC 1191 Path MTU discovery  
RFC 1518 An architecture for IP address allocation with CIDR  
RFC 1519 Classless Inter-Domain Routing (CIDR)  
RFC 1542 Clarifications and extensions for BootP  
RFC 1591 Domain Name System (DNS)  
RFC 1812 Requirements for IPv4 routers  
RFC 1918 IP addressing  
RFC 2581 TCP congestion control

**IPv6 Features**

RFC 1981 Path MTU discovery for IPv6  
RFC 2460 IPv6 specification  
RFC 2464 Transmission of IPv6 packets over Ethernet networks  
RFC 3484 Default address selection for IPv6  
RFC 3587 IPv6 global unicast address format  
RFC 3596 DNS extensions to support IPv6  
RFC 4007 IPv6 scoped address architecture  
RFC 4193 Unique local IPv6 unicast addresses  
RFC 4213 Transition mechanisms for IPv6 hosts and routers  
RFC 4291 IPv6 addressing architecture  
RFC 4443 Internet Control Message Protocol (ICMPv6)  
RFC 4861 Neighbor discovery for IPv6  
RFC 4862 IPv6 Stateless Address Auto-Configuration (SLAAC)  
RFC 5014 IPv6 socket API for source address selection

RFC 5095 Deprecation of type 0 routing headers in IPv6  
RFC 5175 IPv6 Router Advertisement (RA) flags option  
RFC 6105 IPv6 Router Advertisement (RA) guard

**Management**

AT Enterprise MIB with AMF MIB and SNMP traps  
Optical DDM MIB  
SNMPv1, v2c and v3  
IEEE 802.1ABLink Layer Discovery Protocol (LLDP)  
RFC 1155 Structure and identification of management information for TCP/IP-based Internets  
RFC 1157 Simple Network Management Protocol (SNMP)  
RFC 1212 Concise MIB definitions  
RFC 1213 MIB for network management of TCP/IP-based Internets: MIB-II  
RFC 1215 Convention for defining traps for use with the SNMP  
RFC 1227 SNMP MUX protocol and MIB  
RFC 1239 Standard MIB  
RFC 2578 Structure of Management Information v2 (SMIv2)  
RFC 2579 Textual conventions for SMIv2  
RFC 2580 Conformance statements for SMIv2  
RFC 2674 Definitions of managed objects for bridges with traffic classes, multicast filtering and VLAN extensions  
RFC 2741 Agent extensibility (AgentX) protocol  
RFC 2787 Definitions of managed objects for VRRP  
RFC 2819 RMON MIB (groups 1,2,3 and 9)  
RFC 2863 Interfaces group MIB  
RFC 3164 Syslog protocol  
RFC 3176 sFlow: a method for monitoring traffic in switched and routed networks  
RFC 3411 An architecture for describing SNMP management frameworks  
RFC 3412 Message processing and dispatching for the SNMP  
RFC 3413 SNMP applications  
RFC 3414 User-based Security Model (USM) for SNMPv3  
RFC 3415 View-based Access Control Model (VACM) for SNMP  
RFC 3416 Version 2 of the protocol operations for the SNMP  
RFC 3417 Transport mappings for the SNMP  
RFC 3418 MIB for SNMP  
RFC 3621 Power over Ethernet (PoE) MIB

- RFC 3635 Definitions of managed objects for the Ethernet-like interface types
- RFC 3636 IEEE 802.3 MAU MIB
- RFC 4022 MIB for the Transmission Control Protocol (TCP)
- RFC 4113 MIB for the User Datagram Protocol (UDP)
- RFC 4188 Definitions of managed objects for bridges
- RFC 4292 IP forwarding table MIB
- RFC 4293 MIB for the Internet Protocol (IP)
- RFC 4318 Definitions of managed objects for bridges with RSTP
- RFC 4560 Definitions of managed objects for remote ping, traceroute and lookup operations
- RFC 6527 Definitions of managed objects for VRRPv3

- RFC 2697 A single-rate three-color marker
- RFC 2698 A two-rate three-color marker
- RFC 3246 DiffServ Expedited Forwarding (EF)

**Resiliency Features**

- ITU-T G.8023 / Y.1344 Ethernet Ring Protection Switching (ERPS)
- IEEE 802.1AX Link aggregation (static and LACP)
- IEEE 802.1D MAC bridges
- IEEE 802.1s Multiple Spanning Tree Protocol (MSTP)
- IEEE 802.1w Rapid Spanning Tree Protocol (RSTP)
- IEEE 802.3ad Static and dynamic link aggregation
- RFC 5798 Virtual Router Redundancy Protocol version 3 (VRRPv3) for IPv4 and IPv6

**Security Features**

- SSH remote login
- SSLv2 and SSLv3
- TACACS+ Accounting, Authentication and Accounting (AAA)
- IEEE 802.1X authentication protocols (TLS, TTLS, PEAP and MD5)
- IEEE 802.1X multi-suplicant authentication
- IEEE 802.1X port-based network access control
- RFC 2818 HTTP over TLS ("HTTPS")
- RFC 2865 RADIUS authentication
- RFC 2866 RADIUS accounting
- RFC 2868 RADIUS attributes for tunnel protocol support
- RFC 3280 Internet X.509 PKI Certificate and Certificate Revocation List (CRL) profile
- RFC 3546 Transport Layer Security (TLS) extensions
- RFC 3579 RADIUS support for Extensible Authentication Protocol (EAP)
- RFC 3580 IEEE 802.1x RADIUS usage guidelines
- RFC 3748 PPP Extensible Authentication Protocol (EAP)
- RFC 4251 Secure Shell (SSHv2) protocol architecture
- RFC 4252 Secure Shell (SSHv2) authentication protocol
- RFC 4253 Secure Shell (SSHv2) transport layer protocol
- RFC 4254 Secure Shell (SSHv2) connection protocol
- RFC 5246 TLS v1.2

**Services**

- RFC 854 Telnet protocol specification
- RFC 855 Telnet option specifications
- RFC 857 Telnet echo option
- RFC 858 Telnet suppress go ahead option
- RFC 1091 Telnet terminal-type option
- RFC 1350 Trivial File Transfer Protocol (TFTP)
- RFC 1985 SMTP service extension
- RFC 2049 MIME
- RFC 2131 DHCPv4 (server, relay and client)
- RFC 2132 DHCP options and BootP vendor extensions
- RFC 2616 Hypertext Transfer Protocol - HTTP/1.1
- RFC 2821 Simple Mail Transfer Protocol (SMTP)
- RFC 2822 Internet message format
- RFC 3046 DHCP relay agent information option (DHCP option 82)
- RFC 3315 DHCPv6 (server, relay and client)
- RFC 3633 IPv6 prefix options for DHCPv6
- RFC 3646 DNS configuration options for DHCPv6
- RFC 3993 Subscriber-ID suboption for DHCP relay agent option
- RFC 4330 Simple Network Time Protocol (SNTP) version 4
- RFC 5905 Network Time Protocol (NTP) version 4

**VLAN Support**

- Generic VLAN Registration Protocol (GVRP)
- IEEE 802.1ad Provider bridges (VLAN stacking, Q-in-Q)
- IEEE 802.1Q Virtual LAN (VLAN) bridges
- IEEE 802.1v VLAN classification by protocol and port
- IEEE 802.3ac VLAN tagging

**Voice over IP (VoIP)**

- LLDP-MED ANSI/TIA-1057
- Voice VLAN

**Multicast Support**

- IGMP query solicitation
- IGMP snooping (IGMPv1, v2 and v3)
- IGMP snooping fast-leave
- IGMP/MLD multicast forwarding (IGMP/MLD proxy)
- MLD snooping (MLDv1 and v2)
- RFC 1112 Host extensions for IP multicasting (IGMPv1)
- RFC 2236 Internet Group Management Protocol v2 (IGMPv2)
- RFC 2710 Multicast Listener Discovery (MLD) for IPv6
- RFC 2715 Interoperability rules for multicast routing protocols
- RFC 3306 Unicast-prefix-based IPv6 multicast addresses
- RFC 3376 IGMPv3
- RFC 3810 Multicast Listener Discovery v2 (MLDv2) for IPv6
- RFC 4541 IGMP and MLD snooping switches

**Quality of Service (QoS)**

- IEEE 802.1p Priority tagging
- RFC 2211 Specification of the controlled-load network element service
- RFC 2474 DiffServ precedence for eight queues/port
- RFC 2475 DiffServ architecture
- RFC 2597 DiffServ Assured Forwarding (AF)



AT-IX5-28GPX Front view



AT-IX5-28GPX Rear view with 1 power supply



AT-IX5-28GPX Rear view with 2 power supplies

## Ordering Information

### Switch and Power Supply options



**AT-IX5-28GPX-00**  
24-port 10/100/1000BASE-T stackable PoE+ switch with 4 SFP+ ports and 2 power supply bays  
*Note: Power supplies ordered separately*



**AT-PWR800-xx**  
800W AC system and PoE+ power supply

Where xx = 10 for US power cord  
20 for no power cord  
30 for UK power cord  
40 for Australian power cord  
50 for European power cord



### 10GbE SFP+ Modules

**AT-SP10SR\*\***  
10GSR 850 nm short-haul, 300 m with MMF

**AT-SP10SR/I**  
10GSR 850 nm short-haul, 300 m with MMF industrial temperature

**AT-SP10LRM**  
10GLRM 1310 nm short-haul, 220 m with MMF

**AT-SP10LR\*\***  
10GLR 1310 nm medium-haul, 10 km with SMF

**AT-SP10LR/I**  
10GLR 1310 nm medium-haul, 10 km with SMF industrial temperature

**AT-SP10LR20/I**  
10GER 1310nm long-haul, 20 km with SMF industrial temperature

**AT-SP10ER40/I\*\***  
10GER 1310nm long-haul, 40 km with SMF industrial temperature

**AT-SP10ZR80/I\*\***  
10GER 1550nm long-haul, 80 km with SMF industrial temperature

**AT-SP10TW1**  
1 meter SFP+ direct attach cable

**AT-SP10TW3**  
3 meter SFP+ direct attach cable

**AT-SP10TW7**  
7 meter SFP+ direct attach cable

### SFP Modules

**AT-SPSX**  
1000SX GbE multi-mode 850nm fiber up to 550m

**AT-SPSX/I**  
1000SX GbE multi-mode 850nm fiber up to 550m industrial temperature

**AT-SPEX**  
1000X GbE multi-mode 1310nm fiber up to 2km

**AT-SPLX10**  
1000LX GbE single-mode 1310nm fiber up to 10km

**AT-SPLX10/I**  
1000LX GbE single-mode 1310nm fiber up to 10km industrial temperature

**AT-SPBD10-13**  
1000LX GbE Bi-Di (1310nm Tx, 1490nm Rx) fiber up to 10km

**AT-SPBD10-14**  
1000LX GbE Bi-Di (1490nm Tx, 1310nm Rx) fiber up to 10km

**AT-SPLX40**  
1000LX GbE single-mode 1310nm fiber up to 40km

**AT-SPZX80**  
1000ZX GbE single-mode 1550nm fiber up to 80km

**AT-SPBD20-13/I**  
1000BX GbE Bi-Di (1310 nm Tx, 1550 nm Rx) fiber up to 20 km

**AT-SPBD20-14/I**  
1000BX GbE Bi-Di (1490 nm Tx, 1310 nm Rx) fiber up to 20 km

\*\* These modules support dual-rate 1G/10G operation

### Feature Licenses

NAME	DESCRIPTION	INCLUDES	STACK LICENSING
<b>AT-FL-IX5-EPSR</b>	IX5 EPSR Master and UDLD License	▶ EPSR Master ▶ UDLD	▶ One license per stack member
<b>AT-FL-IX5-8032</b>	ITU-T G.8032 license	▶ G.8032 ring protection ▶ Ethernet CFM	▶ One license per stack member